

USER INSTRUCTIONS

PRODUCT FEATURES AND RANGE OF APPLICATION

The BetterDecor roman blind motor is characterized by its small size, large loading capacity and very easy installation, usage and concealment. In its small body, it combines a central motor, two decelerators and outputs for insertion of shafts at both ends. These features are all specifically designed for the BetterDecor roman blind motor. The projection of the headrail for the motor is only 42mm. The motor is suitable for Roman blinds, Austrian blinds and any other corded cloth blinds. It can be operated for a maximum running time of 4 minutes and is not suitable for situations of excessively frequent and prolonged operation.

PRODUCT STRUCTURE

The **BetterDecor roman blind motor** consists of five main parts: a motor, a brake, two decelerators (and two outputs for shaft insertion) and an external control unit. For an external view of the motor, refer to Figure 1.

The **external control unit** (receiver) allows for smooth running of the motor, accurate positioning of the blind and overall safe operation. The control and data cables are connected to the corresponding cables of the motor, and the power cable is connected to a 240V power supply. The external control unit also features a safety device that stops the motor once the blind reaches its topmost position. Refer to Figure 2

The **Remote Control Handset** features 5 control buttons: UP, DOWN, LEFT, RIGHT and STOP. The UP and DOWN buttons control the blind's vertical movement. The LEFT and RIGHT buttons are for channel selection or settings. Refer to Figure 3.

The RIGHT button is for the channel's number to increase from channel 1 to 11 (or from the channel of last transaction), and the LEFT button is for the channel's number to reduce from channel 11 to 1 (or from the channel of last transaction). Refer to Figure 3.

One handset is capable of numerous operations. It can:

- Operate up to 11 motors individually; one on each channel.
- Operate up to 10 motors individually on channels 1 to 10. Channel 11 can be programmed to operate all 10 motors as a group simultaneously.
- Operate up to 11 groups of motors; each group is operated independently of each other. Each group can contain any number of motors and all motors within the group operate simultaneously.
- Each motor can be programmed onto six different channels.

The last transmitted channel will be retained by the handset for the next transmission.

The remote handset will operate reliably up to 30 meters away from the motor inside buildings and up to 100 meters away from the motor in open areas. A Wall holder for the handset is supplied for easy positioning at a permanent location on a wall. The battery life is approximately two years if the handset is used only a few times per day.

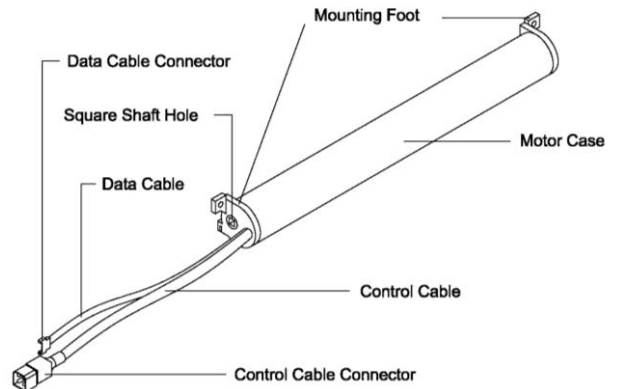

Figure 1

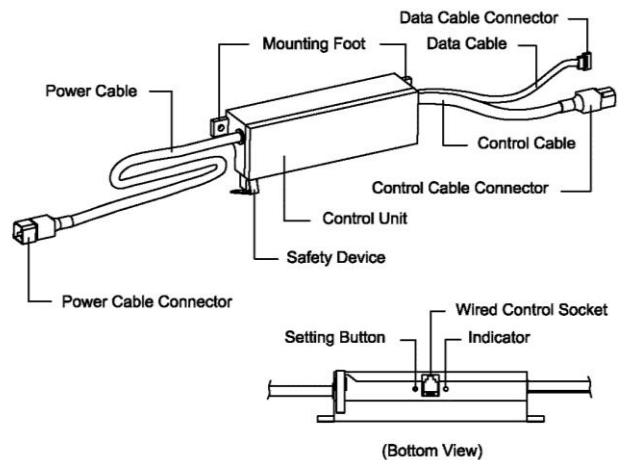

Figure 2

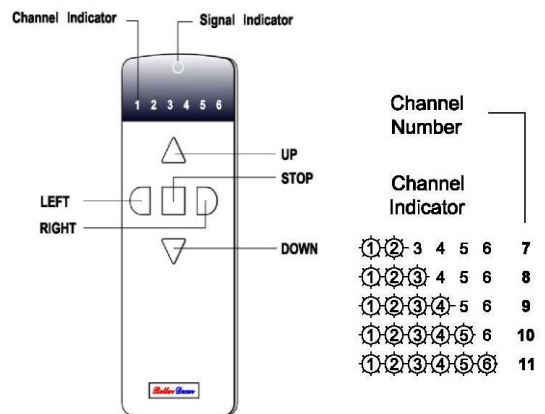

Figure 3

MOTORIZED SYSTEM ASSEMBLY

ROMAN BLIND SINGLE MOTORISED SYSTEM

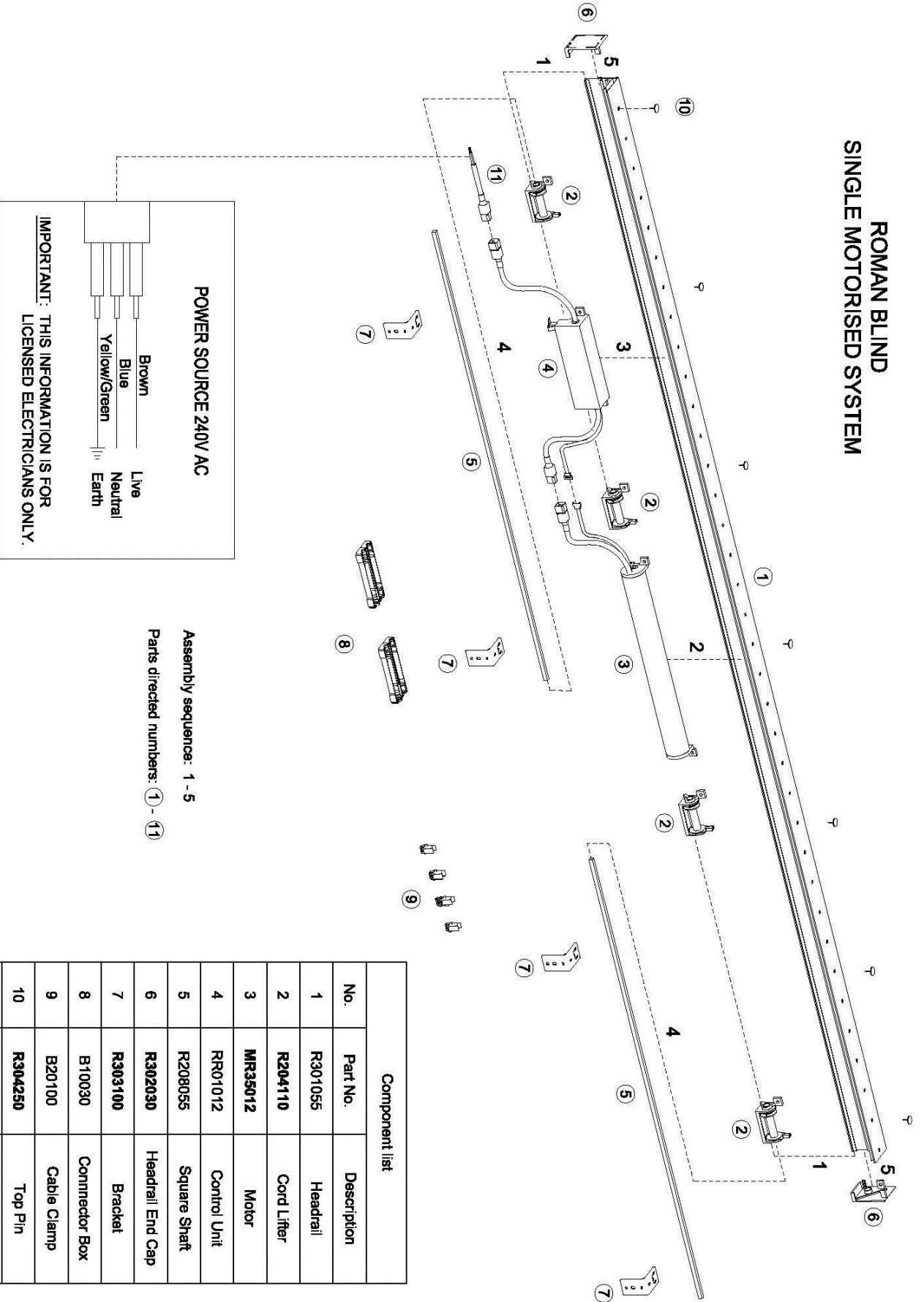

Figure 4

Step 1. Prepare Headrail

- Cut a headrail to the required length.
- Insert cord lifters from any end of the headrail such that the fitting slot of the cord lifter is sitting on the headrail's components sitting bar (Refer to Figure 17) and screw them into place as desired through its mounting foot. Refer to Figure 5.

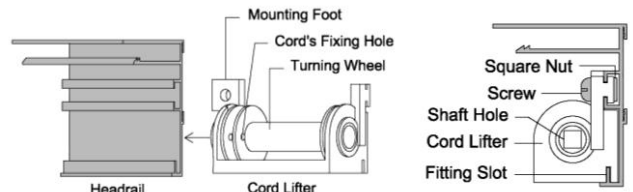

Figure 5

For a diagram of the completion of Step 1, refer to Figure 6.

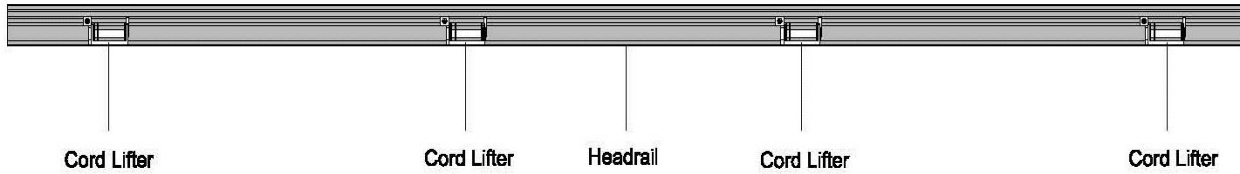

Figure 6

Step 2. Fit Motor

- Place the motor onto the headrail (generally in the center of a headrail) such that the fitting slot at the bottom of the motor is sitting on the headrail's components sitting bar (Figure 17). Then screw the motor onto the headrail's components fitting slot (Figure 17) through its mounting foot. Refer to Figure 7.
- Place a control unit in the headrail at a suitable location to the left of the motor (when facing the back of the blind), allowing an appropriate distance between the motor and the control unit, such that the fitting slot at the bottom of the control unit is sitting on the headrail's components sitting bar and screw the control unit to the headrail's components fitting slot through its mounting foot. Refer to Figure 8.
- Connect the control and data cables of the motor (Figure 1) and control unit (Figure 2) accordingly, then place the control cable connectors into a connector box and lock it. Refer to Figure 9.

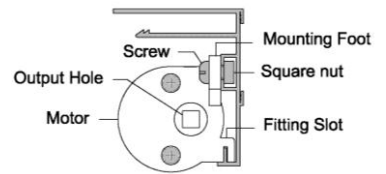

Figure 7

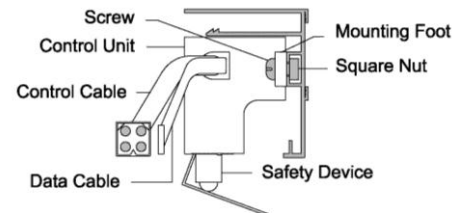

Figure 8

For a diagram of the completion of Step 2, refer to Figure 10.

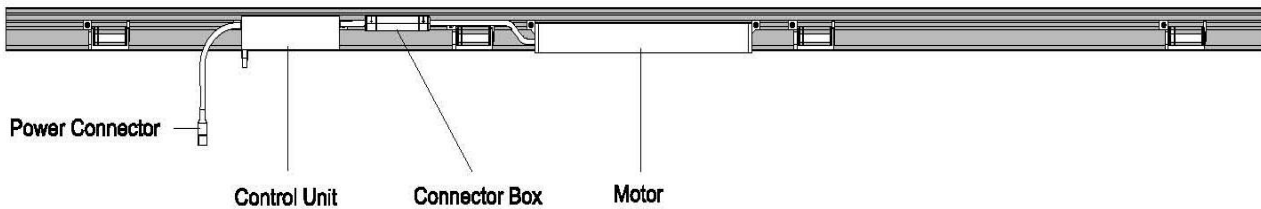

Figure 10

Step 3. Finish Assembly

- Place a few cable clamps onto the components fitting slot of the headrail at suitable locations to clamp both control and data cables securely. Refer to Figure 11.
- To obtain the cutting length of the square shafts, measure the distance from both ends of the motor to the relevant end of the headrail (In Figure 12, it is A and B, plus 8mm). Cut and thread both square shafts through the cord lifters and insert into the motor's square shaft hole. Ensure that all turning wheels of the cord lifters are aligned (according to the cord fixing holes on the turning wheels).
- Cover both ends of the headrail with headrail end caps.
- Finally, thread blind cords (1.2mm diameter cord) through the cord fixing holes of the turning wheels, ensuring that the blind cords are threaded through the cord fixing holes at the same position on all the turning wheels. Ensure that all cords are not wound around the turning wheels. It is now ready for a blind to be attached to the operating system.

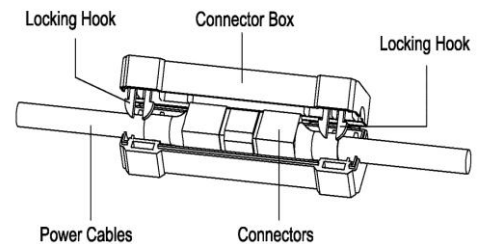

Figure 9

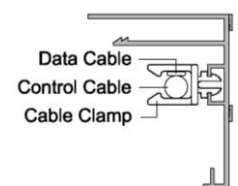

Figure 11

For a diagram of the completion of Step 3, refer to Figure 12.

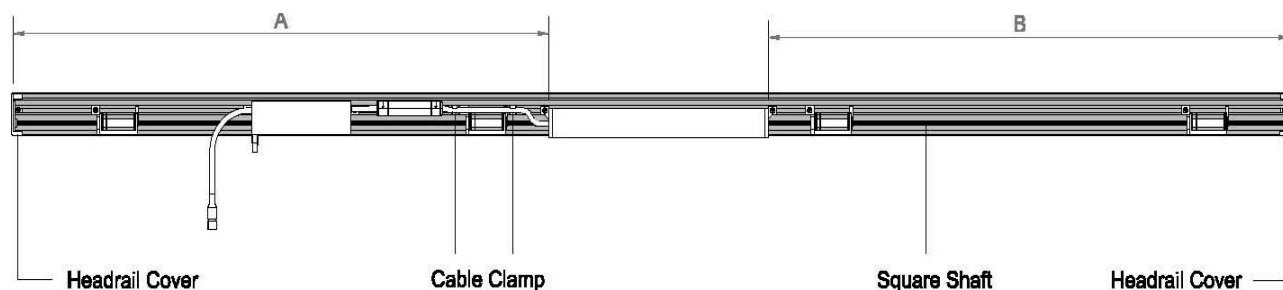

Figure 12

INSTALLATION OF A BLIND

1. Attach a roman blind to the headrail, either to the front of the headrail with velcro tape or to the top of the headrail with double sided adhesive tape and top pins spaced about 300mm apart (Refer to Figure 13 for top attachment). Then thread cords through the rings and knot cords around the bottom rings of the blind.
2. Install a number of brackets on the wall at the same height (usually each bracket is 500 to 600mm apart). Level the headrail and push it into the brackets such that the brackets are inserted into the mounting slot of the headrail (Refer to Figure 14). The headrail must be pushed until it cannot be pushed any further.
3. Plug the control unit's power connector to the 240V power lead installed on right hand side of the blind (Refer to Figure 4 for wiring diagram), then place the power cable connectors into a connector box and lock it (Refer to Figure 9). The control unit will emit a long beep to signal that power supply is ready.

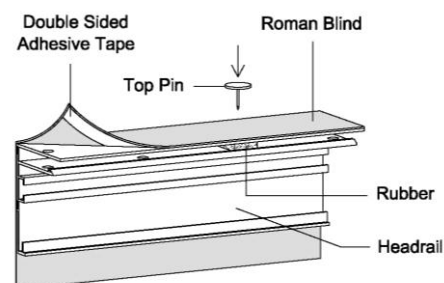
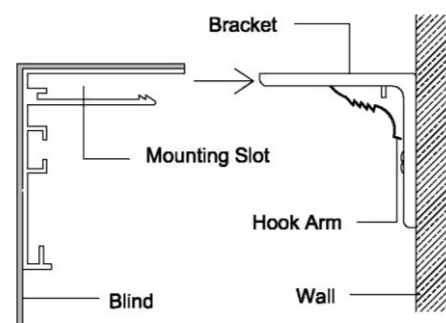

Figure 13

To uninstall a blind

1. Switch off the power, remove the power cable connector box and unplug the power cable.
2. Push the hook arm of the bracket upwards until it is fixed in place.
3. Pull out the headrail and release the hook arm of the headrail back into its natural position for next use.



TRANSMISSION CODE (CHANNEL) SETTING (UP TO 24 CHANNELS ONTO A MOTOR)

Selecting the first channel for a motor

Ensure that the motor and receiver are installed within a complete system and that the system is ready to be programmed, otherwise any operation of programming should not be attempted.

1. Press the setting button on the bottom of the control unit (Refer to Figure 2). It will emit 1 short beep to indicate readiness for the first channel number to be selected.
2. Press the setting button on the back of the remote control handset to release all channels to choose from.
3. Press the LEFT or RIGHT buttons on the remote control handset to select a desired channel.
4. Press the STOP button on the handset whilst the channel indicator light for the selected channel is still bright. The control unit will emit a long beep to confirm that it is in communication with the remote control handset on the selected channel.

At this stage, the UP or DOWN buttons cause only micro stepping (Refer to **Micro Stepping** below) and the control unit will emit a short beep.

Programming the same motor onto a second channel

A motor that has been programmed for individual control on its own channel can also be programmed onto a second channel, along with other motors, for group control.

1. Press the setting button on the bottom of the control unit again; it will emit 2 short beeps to indicate that the motor is programming onto a second channel (the number of beeps the motor emits will correspond to the number of channels on which the motor is channeled, e.g. if the motor is being programmed onto a third channel, then it will emit 3 short beeps).
2. Press the setting button on the back of the remote control handset to release all channels to choose from.
3. Press the LEFT or RIGHT buttons on the remote control handset to choose a channel that has not been used for the motor (If the control unit emits 5 rapid beeps, it is indicating that the channel selected has already been used for the motor. The process must then be repeated from step 1.)
4. Press the STOP buttons on the handset whilst the channel indicator light for the selected channel is still bright. The control unit will emit a long beep to confirm that it is in communication with the remote control handset on the second selected channel.

One motor can be programmed on up to 24 channels. If the motor has already been programmed onto all 24 channels, the control unit will emit 5 rapid beeps.

Note: All other unselected channels have been blocked.

DELETION

If a motor has been programmed onto any channel(s) that need to be changed, then all channels must be deleted first and the steps from 'Selecting the first channel for a motor' must be repeated.

Channel deletion only: Press and hold the setting button on the bottom of the control unit for 3 seconds. The control unit will emit 2 short beeps to indicate that all channel settings between the motor and the remote control handset have been deleted. (Note: at this stage all limit settings remain undeleted if limit settings have already been set up.)

Both channel and limit setting deletion: Press and hold the setting button on the bottom of the control unit for 5 seconds. The control unit will first emit 2 short beeps. Continue to hold the button until a long beep is emitted to indicate that all channel settings between the motor and the remote control handset and all limit settings have been deleted.

LIMIT SETTING

Check the motor direction by pressing the UP or DOWN button before limit settings.

Change the direction if needed (refer to **EXCHANGE THE MOTOR DIRECTION** below).

Before limit setting, ensure that the blind is fully released (Refer to Figure 15) . All setting operations are on the remote control handset only. Move the blind cords' knots on the turning wheels to the lowest position by pressing the UP or DOWN buttons if needed (Refer to Figure 16).

Getting into setting mode

1. Press and hold the setting button on the back of the remote control handset for 3 seconds, the control unit will emit 3 long beeps to indicate that the system is in limit setting mode.

Note: Do not press DOWN button at this stage. Always set the upper limit first. This ensures that the system remembers the fully released position of the blind for the lower limit setting. If the DOWN button is pressed before upper limit setting, then the blind will not stop automatically when it reaches its fully released position during lower limit setting (as indicated in Step 7).

Upper Limit

2. Press the UP button to wind the blind up to the desired top limit position.
3. Press the STOP button at desired upper position, or the blind will stop itself when it moves to the topmost position. For finer setting increments press the UP or DOWN buttons for micro stepping if needed (Refer to **Micro Stepping** below). If the blind stopped far away from the desired position, wait for 5 rapid beeps to indicate that the system has exited the setting mode and then return to step 1 to re-start.
4. Press and hold the LEFT button for more than 3 seconds. The control unit will emit a short beep to confirm that the upper limit setting has been completed. (Note: the LEFT button is just for upper limit position's confirmation)

Intermediate Position

5. Press the DOWN button to release the blind down to the desired intermediate position.
6. Press the STOP button at desired intermediate position. For finer setting increments press the UP or DOWN buttons for micro stepping if needed. If the blind stopped far away from the desired position, wait for 5 rapid beeps to indicate that the system has exited the setting mode and then return to step 1 to re-start.
7. Press and hold the STOP button for more than 3 seconds. The control unit will emit 2 short beeps to confirm that the intermediate position setting has been completed. (Note: the STOP button is just for intermediate position's confirmation.)

Lower Limit

8. Press the DOWN button to release the blind down to the desired bottom limit position.
9. Press the STOP button at desired lower position, or the blind will stop itself when it is fully released. For finer setting increments press the UP or DOWN buttons for micro stepping if needed. If the blind stopped far away from the desired position, wait for 5 rapid beeps to indicate that the system has exited the setting mode and then return to step 1 to re-start.
10. Press and hold the RIGHT button for more than 3 seconds. The control unit will emit a long beep to confirm that all limit settings have been completed and the system will enter normal operation mode. (Note: the RIGHT button is just for lower limit position's confirmation)

To reset the blind limit position, the blind must be fully released first (this ensures that the system remembers the fully released position so that the blind can be stopped automatically at that position during lower limit setting). Then repeat steps 1 to 8.

Note: If there is no any operation within 30 seconds after any button is pressed in limit setting mode, the control unit will emit 5 rapid beeps to indicate that the system will exit the setting mode.

Micro Stepping

- Press the STOP button once, approximately 1mm movement each time when the UP or DOWN buttons is pressed.
- Press the STOP button twice, approximately 3mm movement each time when the UP or DOWN buttons is pressed.
- Press the STOP button thrice, approximately 5mm movement each time when the UP or DOWN buttons is pressed.

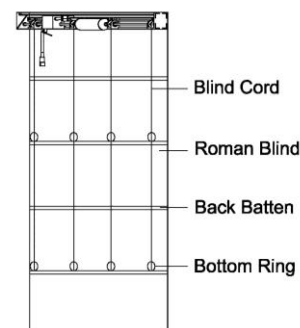

Figure 15

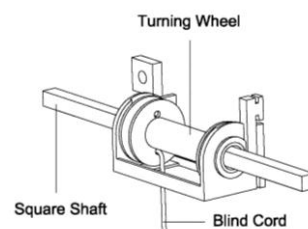

Figure 16

OPERATION

1. Select a channel (if the remote control handset has been released for more than two channels).
2. Press any one of the UP, STOP or DOWN buttons to move the blind to the top limit position, intermediate position or the bottom limit position when the channel indicate of the blind is still on.

EXCHANGE THE MOTOR ROTATION'S DIRECTION

This operation can be done at any time once the motor in communication with the remote control handset on the selected channel.

1. Press and hold the LEFT button for more than 3 seconds. The motor will emit 2 short beeps.
2. Press the UP and DOWN buttons simultaneously, the motor will emit a long beep to confirm that the direction of rotation of the motor has been changed.

C-BUS AND WALL SWITCH CONNECTION

If desired, a wall switch can be connected to the low voltage wired control socket (Refer to Figure 2), however, it is usually not necessary to use or connect the socket if the remote control handset is used. Also a C-Bus relay can be connected to the low voltage socket for home automation. For a C-Bus or wall switch connection diagram, refer to Figure 17.

For a diagram of the wired control socket's output wires that correspond to the relevant remote control functions, refer to Figure 18.

SYSTEM SPECIFICATIONS

Model	BDR35-80-1.1
Voltage	240V / 50Hz
Current	540mA
Power	125W
Speed	80rpm
Maximum Loading	12kg
Operating Cycle	4min
Minimum Blind Width	1100mm
Radio Frequency	433.92MHz
Operating Distance	30 meters indoor
Motor Weight	1.13kg
Motor Size	D35mm X L315mm

HEADRAIL SPECIFICATION

Headrail Profile	52mm (high) X 42mm (projectio
Colour	Silver
Material	Aluminum
Maximum Length	5.5m

Refer to Figure 19

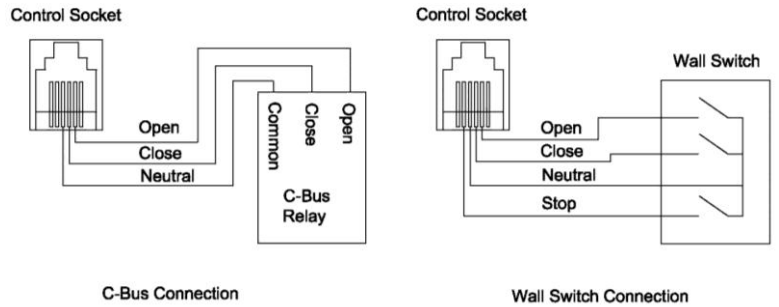

Figure 17

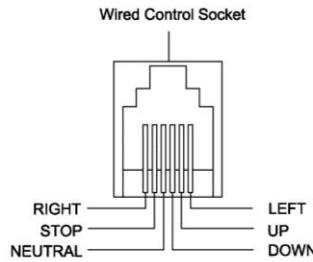

Figure 18

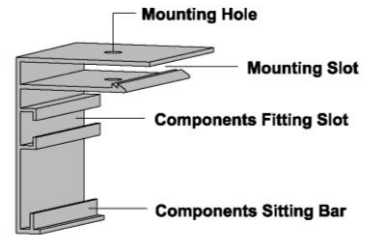

Figure 19

WARNINGS

It is important for the safety of persons to follow these instructions, as incorrect installation can lead to severe injury. Keep these instructions for future reference.

- Before installing the system, remove any unnecessary cords and disable any equipment not needed for powered operation.
- Electrical work must be installed by a licensed electrician in compliance with current safety regulations and these instructions.
- The motor must not be subject to crushing, impact, dropping or contact with any kind of liquid. Do not puncture or penetrate any part of the motor housing.
- The motor has been designed for the automation of Roman blinds and Austrian blinds in residential and commercial environments; any other use is considered improper and is not recommended.
- The supply cable attached to the system can not be replaced. If the cable is damaged, the appliance must be returned to aftersales department in order to avoid danger.
- Loading weight and the operating time must be compatible with the system specifications.
- Before carrying out any form of maintenance, switch off the power to the control unit.
- Use only BetterDecor approved accessories, such as power leads, brackets and transmitters.
- Examine the installation at regular intervals. Do not use the installation until any faults have been rectified and adjustments made.
- Do not allow children to play with any controls. Keep remote controls away from children.

5 YEARS REPLACEMENT WARRANTY

The BetterDecor motor and the control unit are covered by a 5 year warranty from the date of purchase. The remote control handset is covered by a 2 year warranty.

This warranty excludes any defect or failure caused by defacement, misuse, abuse, neglect, accident, misadjustment, incorrect voltage, improper installation, natural disaster (ie; fire, hail, lightening strikes, thunderstorm, flood and corrosion etc), any modification that affects the reliability or performance of the system, installation by unqualified persons or alteration of the serial number.

This warranty shall not be deemed to detract or limit the consumer's rights under any state or federal consumer legislation.

BetterDecor Pty Ltd
www.betterdecor.com.au