

## RollEase Link System Roller Shade Installation Instructions

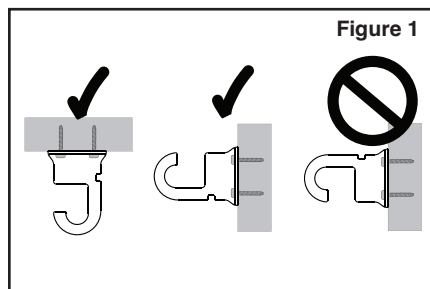

1. Mount the clutch-side bracket, link bracket(s), and pin end side bracket. *Note: This system should always be installed the "J" opening outward or upward, **never facing downward** and requires the use of clutch and pin end brackets with 2 inch (50mm) projections (RB-380, RB-580, SLB-680, or SLNB-680) (See Figure 1)*

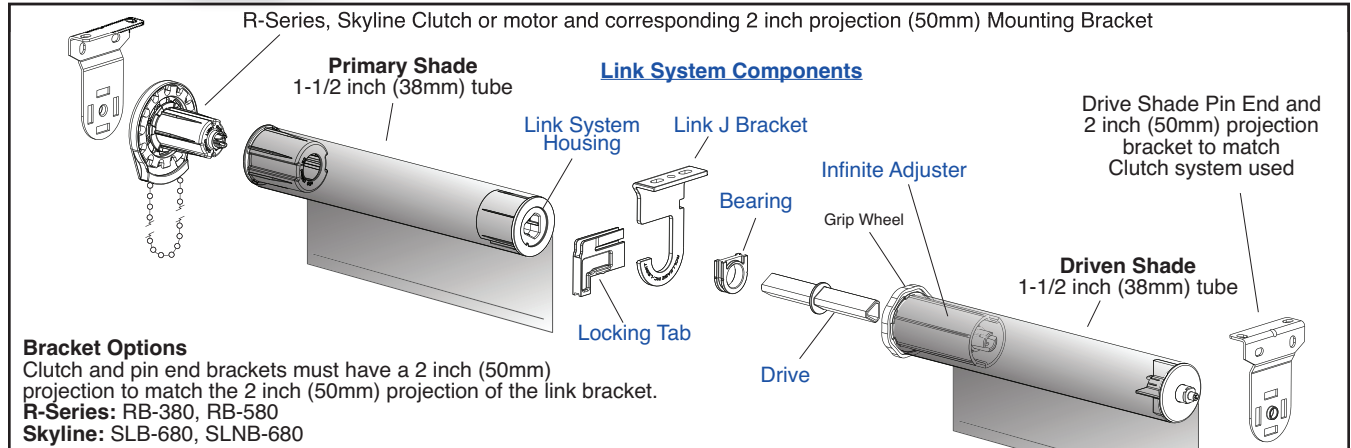
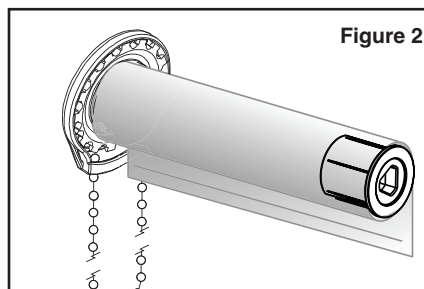

2. Insert the clutch (or motor) into one end of the **Primary** roller shade tube and the housing into the opposite end. (See Figure 2) *Note: The Infinite Adjuster can never be used on the same tube as the clutch (or motor).*

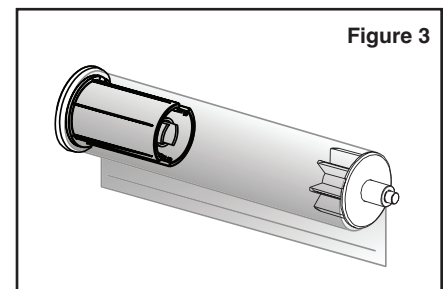

3. Insert the pin end into the furthest end of the **Driven** shade(s) and the Infinite Adjuster into the other end. The Infinite Adjuster will be horizontally opposed to the housing of its neighboring shade. When three shades are being linked, another housing must be inserted in place of the pin end in the middle shade. The pin end will always be at the end of the third shade. (See Figure 3)

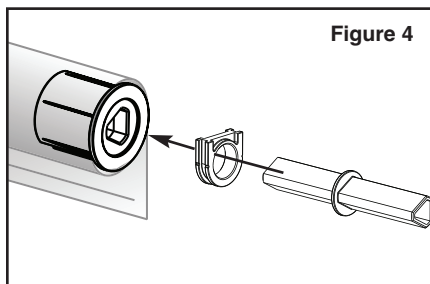

4. Insert one the end of the triangular shaped drive link through the bearing (See Figure 4)

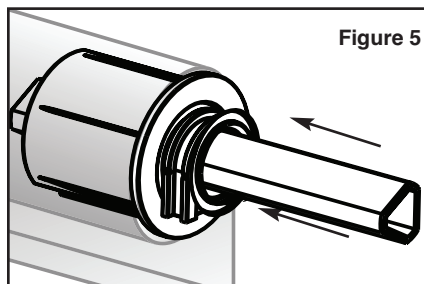

5. Slide the triangular link and bearing onto the housing. (See Figure 5)

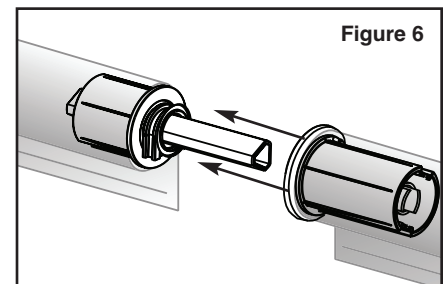

6. Slide the Infinite Adjuster end of the neighboring tube onto the drive. When installing three shades, repeat Steps 4 through 6.

For installation of 3 shades, skip ahead to Step 9

### 7. TWO SHADE INSTALLATION

All the link shades should be connected and installed together treating them as one unit. While the ends of the shades that are being linked are supported, insert the clutch and pin end into their respective brackets. This will cause the shades to bow down in a "V"-like shape. If the shades are large this will require two installers. The shades require support and should not be left to hang by the clutch and pin end alone. (See Figure 7)

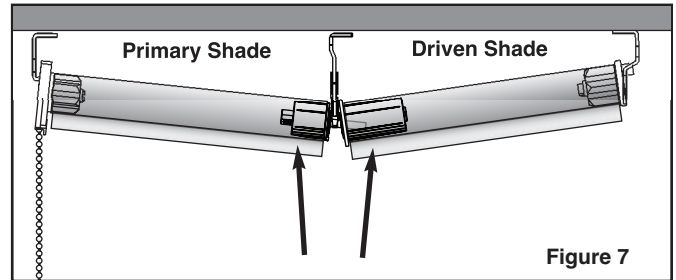
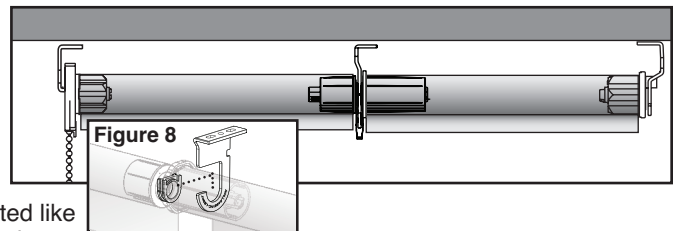

Figure 7

8. Slide the assembly up and over into the J-Bracket making sure the curved edge of the bearing faces the matching curve in the J-bracket. (See Figure 8) Skip ahead to Step 11



### 9. THREE SHADE INSTALLATION

When installing three shades, all tubes must be connected and treated like they are all one shade being installed. While the ends of the shades that are being linked are supported, insert the clutch and pin end into their respective brackets. This will cause the shades to bow down in a "V"-like shape. If the shades are large this will require multiple installers. The shades require support and should not be left to hang by the clutch and pin end alone. (See Figure 9) The clutch and pin end must be inserted before all tubes in the assembly are simultaneously lifted into position in the link brackets. It is not possible to install one shade at a time; unless it is in an outside mount with ample room on either side.

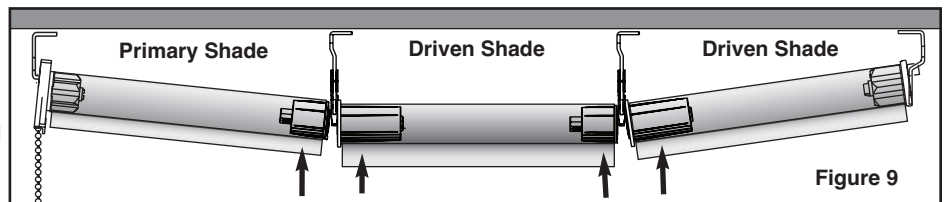
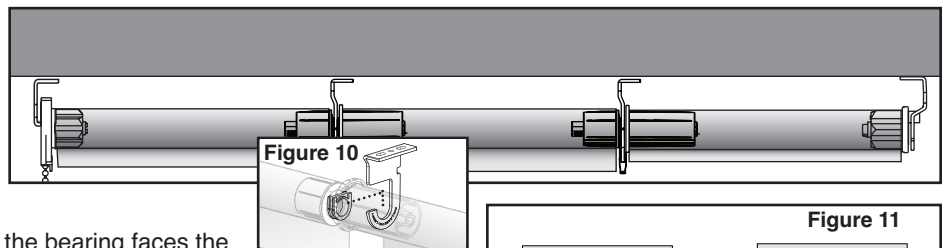

Figure 9

10. Slide the assembly up and over into the J-Bracket making sure the curved edge of the bearing faces the matching curve in the J-bracket. (See Figure 10)



11. Insert the locking tab securely onto the J-Brackets. When properly installed you should hear or feel a latching of the parts. (See Figure 11)

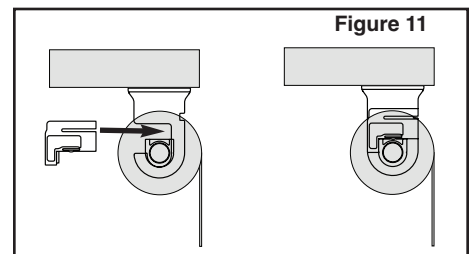

Figure 11

12. Once secured, use the grip wheel on the Infinite Adjuster to adjust the shade on the corresponding tube until it becomes level with the shade on the clutch tube. The level of adjustment is infinitely fine due to RollEase's patented technology. (Figure 12)

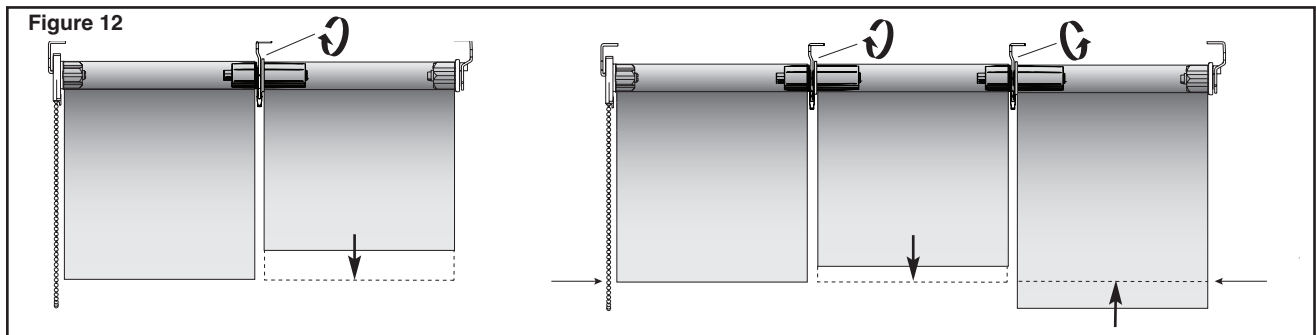

Figure 12

[www.rollease.com](http://www.rollease.com)

RollEase Headquarters  
200 Harvard Avenue - Stamford, CT 06902-6320 USA  
Office: 800.552.5100 203.964.1573  
Fax: 203.964.0513 Order Fax: 203.358.5865

RollEase West  
7150 West Roosevelt Street, Suite-A-155  
Phoenix, AZ 85043 USA  
Office: 623.936.5818 Fax: 623.936.5294

**RollEase®**  
ENGINEERED TO BE ESSENTIAL®